



Exploring the Opal SoC and T8 FPGA

using the Trion T8 BGA81 Development Board

UG-RISCV-OPAL8-v1.1
November 2021
www.elitestek.com



Contents

Introduction.....	iv
VexRiscv RISC-V Core.....	v
Required Hardware.....	v
Required Software.....	v
Chapter 1: Install Software and SoC.....	7
Install the Example Design.....	7
Install the Efinity® Software.....	8
Install the RISC-V SDK.....	8
Install the Java JRE.....	8
Chapter 2: Program the Board with the Opal RTL Design.....	10
About the Example Design.....	10
Connect the FTDI Chip Cable.....	11
Install USB Drivers.....	11
Program the Development Board.....	12
Chapter 3: IP Manager.....	13
Customizing the Opal SoC.....	14
Modify the Bootloader.....	15
Chapter 4: Simulate.....	16
Chapter 5: Launch Eclipse.....	17
Set Global Environment Variables.....	17
Chapter 6: Create and Build a Software Project.....	19
Create a New Project.....	19
Import Project Settings (Optional).....	19
Enable Debugging.....	20
Build.....	20
Chapter 7: Debug with the OpenOCD Debugger.....	21
Import the Debug Configuration.....	21
Debug.....	22
Chapter 8: Create Your Own RTL Design.....	24
Create a Custom APB3 Peripheral.....	24
Remove Unused Peripherals from the RTL Design.....	24
Target Your Own Board.....	25
Chapter 9: Create Your Own Software.....	26
Deploying an Application Binary.....	26
Boot from a Flash Device.....	26
Boot from the OpenOCD Debugger.....	27
Copy a User Binary to the Flash Device.....	27
About the Board Specific Package.....	28
Address Map.....	29
Example Software.....	30
blinkAndEcho Example.....	31
EfxApb3Example.....	31
i2cDemo Example.....	31
readFlash Example.....	31
spiDemo Example.....	32
timerAndGpioInterruptDemo Example.....	32

UartInterruptDemo Example.....	32
userInterruptDemo Example.....	32
writeFlash Example.....	33
Chapter 10: Using a UART Module.....	34
Set Up a USB-to-UART Module (Trion).....	34
Open a Terminal.....	36
Enable Telnet on Windows.....	36
Chapter 11: Troubleshooting.....	37
Error 0x80010135: Path too long (Windows).....	37
OpenOCD Error: timed out while waiting for target halted.....	37
OpenOCD error code (-1073741515).....	38
OpenOCD Error: no device found.....	38
OpenOCD Error: failed to reset FTDI device: LIBUSB_ERROR_IO.....	38
OpenOCD Error: target 'fpga_spinal.cpu0' init failed.....	39
Eclipse Fails to Launch with Exit Code 13.....	39
Efinity® Debugger Crashes when using OpenOCD.....	39
Undefined Reference to 'cosf'.....	39
Chapter 12: API Reference.....	40
Control and Status Registers.....	40
GPIO API Calls.....	41
I ² C API Calls.....	45
I/O API Calls.....	50
Machine Timer API Calls.....	52
PLIC API Calls.....	52
SPI API Calls.....	53
SPI Flash Memory API Calls.....	55
UART API Calls.....	57
Handling Interrupts.....	59
Revision History.....	62

Introduction

易灵思 provides an ultra-light-weight soft RISC-V SoC, called Opal, that you can implement in Trion® FPGAs. The IP Manager in the Efinity® software v2020.2 or higher lets you generate an example design targeting the Trion T20 BGA256 Development Board. To make life simpler for users who want to target the T8 instead, 易灵思 has created an example design that targets the Trion® T8 BGA81 Development Board.



Download: You download the Opal example design for the Trion® T8 BGA81 Development Board from the Support Center (www.elitestek.com/support).

This user guide describes how to:

- Build RTL designs using the Opal RISC-V SoC using an example design targeting the Trion® T8 BGA81 Development Board, and how to extend the example for your own application.
- Set up the software development environment using an example project, create your own software based on example projects, and use the API.

Figure 1: Designing Hardware and Software for the Opal RISC-V SoC

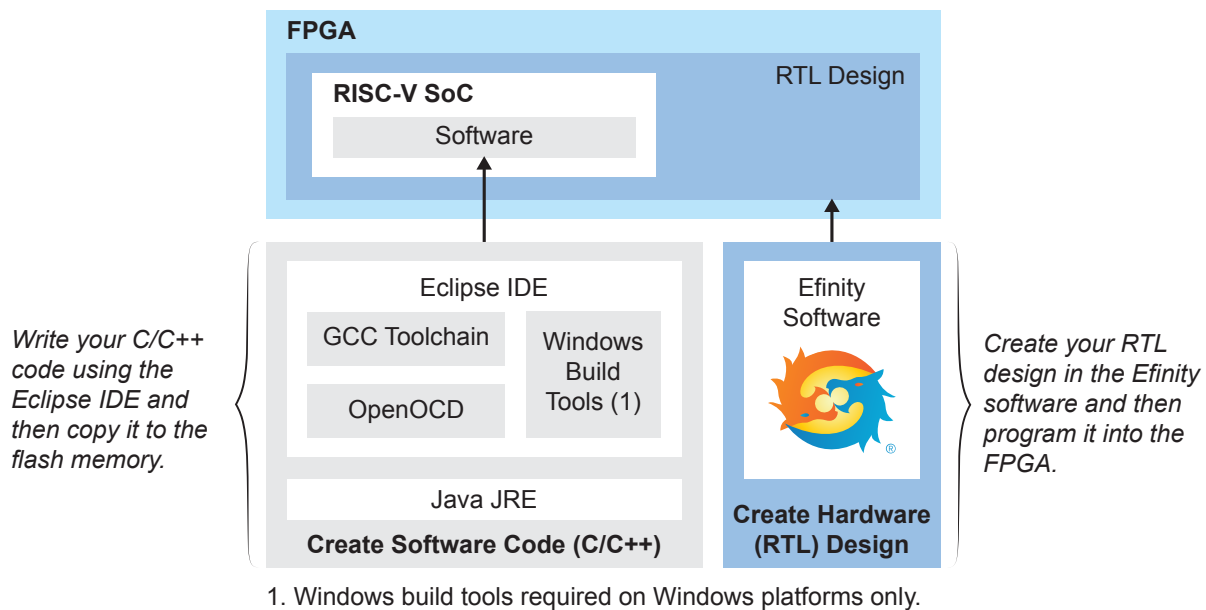

Learn more: Refer to the [Opal RISC-V SoC Data Sheet](#) for detailed specifications on the SoC.

VexRiscv RISC-V Core

The Opal SoC is based on the VexRiscv core created by Charles Papon. The VexRiscv core is a 32-bit CPU using the ISA RISC-V32I with M and C extensions, has five pipeline stages (fetch, decode, execute, memory, and writeback), and a configurable feature set.

In the Opal SoC, the cacheless VexRiscv core supports an APB3 bus interface and can run at speeds up to 0.98 DMIPS/MHz.

The VexRiscv core won first place in the RISC-V SoftCPU contest in 2018.⁽¹⁾

Required Hardware

- Micro-USB cable
- Computer or laptop
- FTDI chip cable, C232HM-DDHSL-0
- (Optional) USB to UART converter module



Note: Some of the software examples provided with the SoC use a UART terminal to display messages. See [Set Up a USB-to-UART Module \(Trion\)](#) on page 34 for more information.

Required Software

To write software for the Opal SoC, you need the following tools. The SDK is available as a single download in the Support Center for Windows and Ubuntu operating systems.

Efinity[®] Software

易灵思[®] development environment for creating RTL designs targeting Trion[®] or 钛金系列 FPGAs. The software provides a complete RTL-to-bitstream flow, simple, easy to use GUI interface, and command-line scripting support.

Version: 2020.2 or higher

RISC-V SDK

Eclipse MCU—Open-source Java-based development environment that uses plug-ins to extend and customize its functionality. The GNU MCU Eclipse plug-in lets you develop applications for ARM and RISC-V cores.

Version: 2020-09 (4.17.0)

Disk space required: 433 MB (Windows), 433 MB (Linux)

xPack GNU RISC-V Embedded GCC—Open-source, prebuilt toolchain from the xPack Project.

Version: 8.3.0-1.1

Disk space required: 1.78 GB (Windows), 1.73 GB (Linux)

OpenOCD Debugger—The open-source Open On-Chip Debugger (OpenOCD) software includes configuration files for many debug adapters, chips, and boards. Many versions of OpenOCD are available. The 易灵思 RISC-V flow requires a custom version of OpenOCD that includes the VexRiscv 32-bit RISC-V processor.

⁽¹⁾ <https://www.businesswire.com/news/home/20181206005747/en/RISC-V-SoftCPU-Contest-Winners-Demonstrate-Cutting-Edge-RISC-V>

Version: 20200421

Disk space required: 9.4 MB (Windows), 7.4 MB (Linux)

GNU MCU Eclipse Windows Build Tool (Windows Only)—This open-source Windows-specific package helps to manage build projects and includes GNU make.

Version: 2.12-20190422-1053

Disk space required: 3.8 MB

Java JRE

Open-source Java 64-bit runtime environment; required for Eclipse.

Version: 8 Update 241

<https://www.java.com/en/download/manual.jsp> (Java 8 official release)

<https://developers.redhat.com/products/openjdk/download> (OpenJDK 8 or 11)

<http://jdk.java.net/16/> (OpenJDK 16)

Install Software and SoC

Contents:

- [Install the Example Design](#)
- [Install the Efinity Software](#)
- [Install the RISC-V SDK](#)
- [Install the Java JRE](#)

Install the Example Design

To install the Opal SoC:

1. Download the file **efx_opal_riscv_soc_t8f81_devkit-v<version>.zip** from the Support Center.
2. Create a directory called **riscv** at the root level of your file system.
3. Unzip the files into the **riscv** directory.

The files are organized in this directory structure:

- **OpalT8_devkit**
 - **embedded_sw**—Software files.
 - **OpalT8**
 - **bsp**—Board specific package for the T8 BGA81 FPGA.
 - **config**—Has the Eclipse project settings file and OpenOCD debug configuration settings files for Windows.
 - **config_linux**—Has the Eclipse project settings file and OpenOCD debug configuration settings files for Linux.
 - **software**—Software examples for the T8 BGA81 Development Board.
 - **tool**—Contains the memory initialization file generator script.
 - **cpu0.yaml**—CPU file for debugging.
 - **ip**—Opal SoC files generated with the IP Manager.
 - **apb3_slave.v**—APB3 slave module.
 - **constraints.sdc**—SDC constraints file.
 - **<name>.bin**—Memory initialization files.
 - **OpalT8_devkit.hex**—Bitstream file.
 - **OpalT8_devkit.peri.xml**—Interface Designer file.
 - **OpalT8_devkit.xml**—Efinity® project file.
 - **top_opalSoc.v**—Top-level RTL file.

Install the Efinity® Software

If you have not already done so, download the Efinity® software from the Support Center and install it. For installation instructions, refer to the [Efinity Software Installation User Guide](#).



Warning: Do not use spaces or non-English characters in the Efinity path.

Install the RISC-V SDK

To install the SDK:

1. Download the file `riscv_sdk_windows-v<version>.zip` or `riscv_sdk_ubuntu-v<version>.zip` from the Support Center.
2. Create a directory for the SDK, such as `c:\riscv-sdk` (Windows) or `home/my_name/riscv-sdk` (Linux).
3. Unzip the file into the directory you created. The complete SDK is distributed as compressed files. You do not need to run an installer.

Windows directory structure:

- **SDK_Windows**
 - `eclipse`—Eclipse application.
 - `GNU MCU Eclipse`—Windows build tools.
 - `openocd`—OpenOCD debugger.
 - `riscv-xtensa-toolchain_8.3.0-1.1_windows`—GCC compiler.
 - `run_eclipse.bat`—Batch file that sets variables and launches Eclipse.
 - `setup.bat`—Batch file to set variables for running OpenOCD on the command line to flash the binary.

Ubuntu directory structure:

- **SDK_Ubuntu<version>**
 - `eclipse`—Eclipse application.
 - `openocd`—OpenOCD debugger.
 - `riscv-xtensa-toolchain_8.3.0-1.1_linux`—GCC compiler.
 - `run_eclipse.sh`—Shell file that sets variables and launches Eclipse.
 - `setup.sh`—Shell file to set variables for running OpenOCD on the command line to flash the binary.

Install the Java JRE

To install the JRE:

1. Download the 64-bit version of the JRE or JDK for your operating system from <https://www.java.com/en/download/manual.jsp> (Java 8 official release) <https://developers.redhat.com/products/openjdk/download> (OpenJDK 8 or 11) <http://jdk.java.net/16/> (OpenJDK 16)
2. Follow the installation instructions on the web site to install the JRE.



Note: You need a 64-bit version of the Java JRE. If you use a 32-bit version, when you try to launch Eclipse you will get an error that Java quit with exit code 13.

Program the Board with the Opal RTL Design

Contents:

- [About the Example Design](#)
- [Connect the FTDI Chip Cable](#)
- [Install USB Drivers](#)
- [Program the Development Board](#)

Before working with software code, 易灵思 recommends that you program your board with the RTL design that instantiates the Opal SoC. The example includes a bitstream file to get you started quickly without having to compile the design in the Efinity[®] software.

About the Example Design

The RTL example design targets the Trion[®] T8 BGA81 Development Kit. The corresponding example software blinks an LED and displays messages on a UART terminal.

The IP Manager configuration for the Opal SoC is:

- 21 MHz frequency
- 4096 RAM size
- Soft TAP is true

Figure 2: Example Design Block Diagram

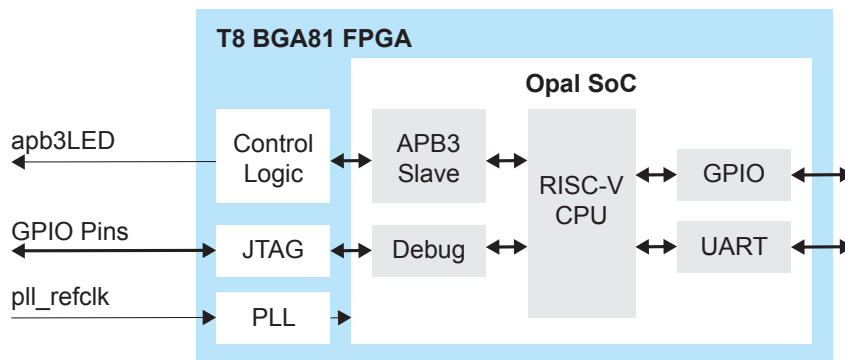

Table 1: Example Design Implementation

Compiled with --optimization_level set to TIMING_1.

FPGA	Logic Utilization (LUTs)	Memory Blocks	f _{MAX} (MHz)	Language	Efinity Version
T8 BGA81 C2	5,165	16	24.233	Verilog HDL	2020.2

Connect the FTDI Chip Cable

The Trion® T8 BGA81 Development Board does not have a JTAG header. Debugging with OpenOCD requires a JTAG interface, so you need to use soft JTAG with the T8 FPGA. The Efinity® project implements a soft JTAG block that assigns GPIO for the 4 JTAG signals (TMS, TDK, TDI, and TDO) to header pins on the Trion® T8 BGA81 Development Board. You connect a C232HM-DDHSL-0 FTDI chip cable to those pins so you can communicate with the T8 FPGA via JTAG for debugging and for downloading the RISC-V firmware.

Figure 3: Connecting the C232HM-DDHSL-0 Cable

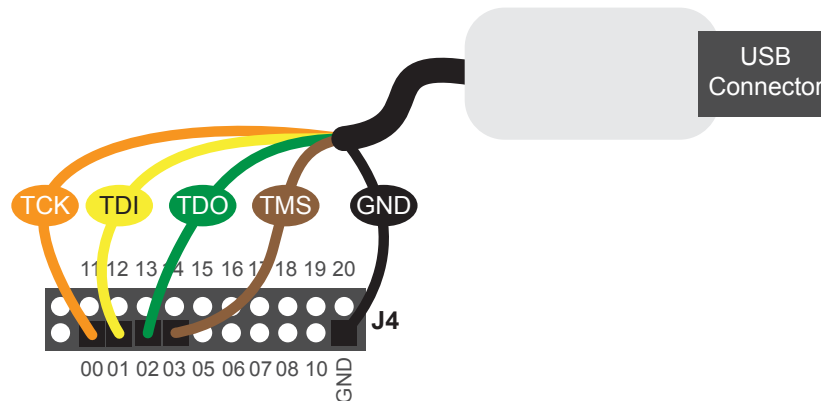

1. Connect the TCK, TDI, TDO, TMS, and GND wires to the Trion® T8 BGA81 Development Board as shown in the figure. The numbers shown are the ones printed on the board.
2. Connect the cable to a USB connector on your computer.
3. Install the driver for the cable as described in the following sections.

Install USB Drivers

The Trion® T8 BGA81 Development Board has an FTDI chip that facilitates communication through the USB connector, and you need to install a driver for it. Additionally, you need to install a driver for the FTDI chip cable. Follow the instructions to install the drivers for Linux or Windows.

Linux Drivers

The following instructions explain how to install a USB driver for Linux operating systems.

1. Disconnect your board from your computer.
2. In a terminal, use these commands:

```
> sudo <installation directory>/bin/install_usb_driver.sh
> sudo udevadm control --reload-rules
```



Note: If your board was connected to your computer before you executed these commands, you need to disconnect and re-connect it.

Windows Drivers

1. Connect the board to your computer with the appropriate cable and power it up.
2. Download the Zadig software from zadig.akeo.ie. (You do not need to install it; simply run the downloaded executable.)
3. Run the Zadig software.



Note: To ensure that the USB driver is persistent across user sessions, run the Zadig software as administrator.

4. Choose **Options > List All Devices**.
5. Turn off **Options > Ignore Hubs or Composite Parents**.
6. Select the Trion® T8 BGA81 Development Board.



Note: The Trion® T8 BGA81 Development Board displays the name **AVR USB HID DEMO** in the Zadig software.

7. Select **libusbK** (*version*) in the **Driver** drop-down list. (This driver works best with OpenOCD.)
8. Click **Replace Driver**.
9. Repeat steps 4 - 8 for the FTDI Chip C232HM-DDHSL-0 programming cable. In step 6, select **FTDIBUS** (*<version>*) and USB ID **0403 6014**.
10. Close the Zadig software.

When you open the Device Manager in the Windows Control Panel, it displays the new USB device driver.

Program the Development Board

The example includes a bitstream file, **OpalT8_devkit.hex**, so you can get started quickly without having to compile the design. Download the **.hex** file to the board using these steps:

1. Connect the Trion® T8 BGA81 Development Board to your computer using a USB cable.
2. Use the Efinity® Programmer and SPI active programming mode to download the bitstream file to the board.



Note: Although you can use any programming mode, 易灵思 recommends using SPI active, which programs the design into the flash device on the board. That way, if you power cycle the board the FPGA configures with the SoC design.



Learn more: Instructions on how to use the Efinity® software and board documentation [are available in the Support Center](#).

IP Manager

Contents:

- Customizing the Opal SoC
- Modify the Bootloader

The RTL design includes an instance of the Opal SoC configured for a 21 MHz frequency and 4K of on-chip RAM. The provided testbench has been customized to work with the RTL design files.

You can use the IP Manager to change the operating frequency or on-chip RAM size. With the Trion® T8 BGA81 Development Board, you need to leave the **Enable Soft JTAG TAP** option set to **True**. (Refer to the IP Manager chapter of the Efinity® Software User Guide for details on the IP Manager.)



Important: If you change the SoC configuration and re-generate the IP, the IP Manager also generates an example design and testbench for the T20 BGA256 Development Board in the **T20F256_devkit** directory. The **run.sh** and **run.bat** for the testbench are updated to point to the files in the **T20F256_devkit** folder instead of the files in **OpalT8_devkit** directory. Therefore, if you re-generate the IP and want to simulate, you need to update the paths in the **run.sh** and **run.bat** files to point to the correct directory.

Customizing the Opal SoC

The core has parameters so you can customize its function. You set the parameters in the General tab of core IP Configuration window.

Table 2: Opal SoC Parameters

Parameter	Options	Description
SoC Operating Frequency (Hz)	20000000 - 300000000	Enter the frequency in Hz. For the example design, if you change the frequency, you need to manually change the PLL setting and SDC timing constraint for io_systemClk to match the new frequency. For T8 FPGAs, the SoC cannot operate higher than about 25 MHz. If you choose a frequency higher than that, the Efinity® software will fail to close timing and the design will intermittently hang in hardware. Default: 80000000
SoC On-Chip Ram Size (Bytes)	4096, 8192, 16384, 32768, 65536, 131072, 262144, 524288	The size of the on-chip block RAM for the SoC. Default: 4096
Enable Soft JTAG TAP	True, False	Choose whether you want to include a soft debug TAP for debugging. False: Default. The SoC uses the JTAG User TAP interface block to communicate with the OpenOCD debugger. True: The SoC has a soft JTAG interface to communicate with the OpenOCD debugger. You need to use this setting for T8 BGA49 or BGA81 designs or if you want to use the soft JTAG interface instead of the JTAG User TAP. After enabling the soft JTAG TAP, you need to manually assign the pins with the Interface Designer.



Important: When running the SoC at high frequencies, 易灵思 recommends that you use the TIMING_1 place and route optimization. To set this option:

1. Open the Project Editor.
2. Click the **Place and Route** tab.
3. Double-click the **Value** cell for **--optimization_level**.
4. Choose **TIMING_1**.
5. Click **OK** and then compile.

Modify the Bootloader

When you generate the Opal SoC, the IP Manager creates a pre-built bootloader **.bin** to target the on-chip RAM size you selected. If you want to create a custom bootloader, use the following instructions.



Note: You need the embedded software example code to make these changes; if you have not already done so, generate it.

Modify the Bootloader Software

First you need to modify the bootloader code:

1. Open the **bootloaderConfig** file in the **embedded_sw/ <SoC module> /bsp/efinix/EfxOpalSoc/app** directory.
2. Change the `#define USER_SOFTWARE_SIZE` parameter for the new on-chip RAM size and save.
3. In Eclipse, create a new project from the makefile in the **embedded_sw/ <SoC module> /software/standalone/bootloader** directory and compile it.

Re-Generate the Memory Initialization Files

Next, you need to re-generate the memory initialization files using the **binGen.py** helper script. You find this script in the `<project> /embedded_sw/ <SoC module> /tool` directory. Use the command:

```
python binGen.py -b bootloader.bin -c opalsoc -t <TAP> -s <RAM size>
```

where:

- `<TAP>` is hard or soft, depending on whether you are using the soft JTAG TAP.
- `<RAM size>` is the on-chip RAM size you want to use.

This command generates the new memory initialization files. Copy these files into the same directory as your project **.xml** file, replacing the existing files.

Compile your design.

Simulate

The Opal SoC has a testbench so you can simulate applications in the ModelSim simulator. The simulation files are located in the **Testbench** directory. These testbench files target the files for the Trion® T8 BGA81 Development Board.



Important: If you change the SoC configuration and re-generate the IP, the IP Manager also generates an example design and testbench for the T20 BGA256 Development Board in the **T20F256_devkit** directory. The **run.sh** and **run.bat** for the testbench are updated to point to the files in the **T20F256_devkit** folder instead of the files in **OpalT8_devkit** directory. Therefore, if you re-generate the IP and want to simulate, you need to update the paths in the **run.sh** and **run.bat** files to point to the correct directory.

To simulate:

1. Open the **run.bat** (Window) or **run.sh** (Linux) file.
2. Change the value of the `MyApp` variable for the software binary you want to use with the simulation. If you do not specify a binary, the simulation defaults to using the `blinkAndEcho` binary.

run.bat—To change or specify a software binary, uncomment the `set MyApp` line by removing the `::` and then enter the filename:

```
::set "MyApp=blinkAndEcho.bin"      :: commented line
set "MyApp=mySoftware.bin"         :: point to user file
```

run.sh—By default, `MyApp` is undefined. Specify a filename for `MyApp`:

```
MyApp="mySoftware.bin"
```

3. (Optional) If you are not using the default, copy the application binary for the software code into the **Testbench** directory.
4. Open a Command Prompt (Windows) or terminal (Linux).
5. Change to the **Testbench** directory.
6. Execute the command `./run.bat` or `./run.sh`.



Note: By default, the memory initialization files contain a bootloader application that fetches the data size corresponding to the on-chip RAM size you selected in the IP Manager. If you want build a custom bootloader, refer to **Modify the Bootloader** on page 15.

Launch Eclipse

Contents:

- **Set Global Environment Variables**

The RISC-V SDK includes the **run_eclipse.bat** file (Windows) or **run_eclipse.sh** file (Linux) that adds executables to your path, sets up environment variables for the Opal BSP, and launches Eclipse. Always use this executable to launch Eclipse; do not launch Eclipse directly.

When you first start working with the Opal SoC, you need to configure your Eclipse workspace and environment. Setting up a global development environment for your workspace means you can store all of your Opal software code in the same place and you can set global environment variables that apply to all software projects in your workspace. You should use a unique workspace for your Opal SoC projects. 易灵思 recommends using the **embedded_sw/OpalT8** directory as the workspace directory.



Note: With IP Manager, you can generate multiple SoCs with different options. Using the **embedded_sw/OpalT8** directory as your workspace means that you can explore more than one SoC by simply switching workspaces.

Follow these steps to launch Eclipse and set up your workspace:

1. Launch Eclipse using the **run_eclipse.bat** file (Windows) or **run_eclipse.sh** file.
2. The launch script prompts you to select your SoC. Type 5 for Opal (T8) and press enter.
3. If this is the first time you are running Eclipse, create a new workspace that points to the **embedded_sw/OpalT8** directory. Otherwise, choose **File > Switch Workspace > Other** to choose an existing workspace directory and click **Launch**.

Set Global Environment Variables

You need to set two environment variables for OpenOCD. It is simplest to set them as global environment variables for all projects in your workspace. Then, you can adjust them as needed for individual projects.

Choose **Window > Preferences** to open the **Preferences** window and perform the following steps.

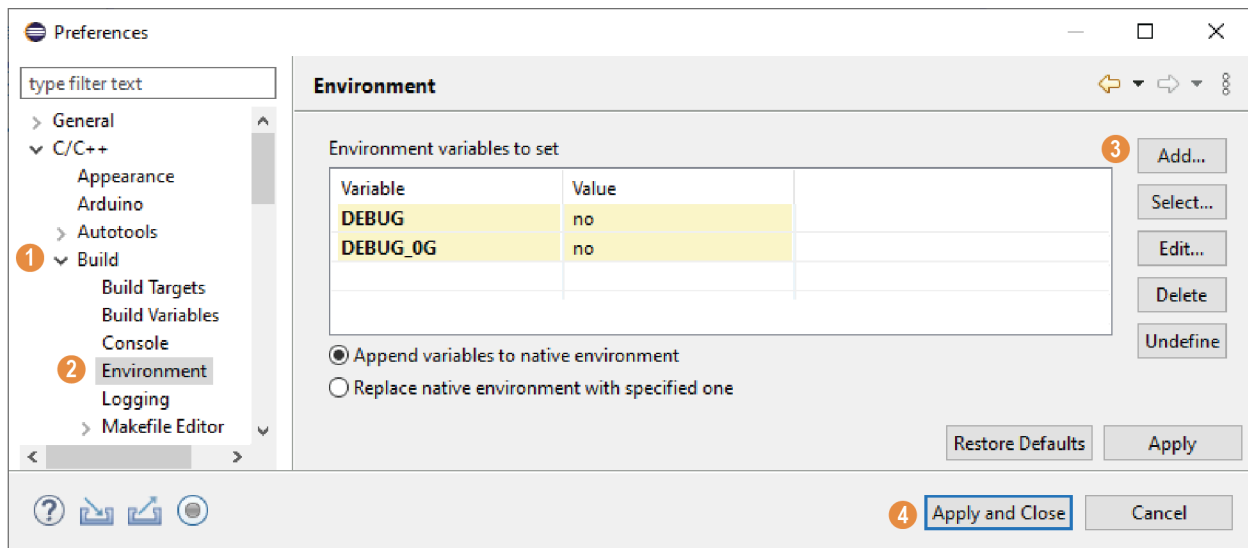

1. In the left navigation menu, expand **C/C++ > Build**.
2. Click **C/C++ > Build > Environment**.
3. Click **Add** and add the following environment variables:

Variable	Value	Description
DEBUG	no	Enables or disables debug mode. no: Debugging is turned off yes: Debugging is enabled
DEBUG_OG	no	Enables or disables optimization during debugging. Use an uppercase letter O not a zero.

4. Click **Apply and Close**.

Create and Build a Software Project

Contents:

- [Create a New Project](#)
- [Import Project Settings \(Optional\)](#)
- [Enable Debugging](#)
- [Build](#)

After you set up your Eclipse workspace, you are ready to create a new project and build it. These instructions walk you through the process using the **blinkAndEcho** example project from the **software** directory.

Create a New Project

In this step you create a new project from the **blinkAndEcho** code example.

1. Launch Eclipse.
2. Select the Opal workspace if it is not open by default.
3. Make sure you are in the C/C++ perspective.

Import the **blinkAndEcho** example:

4. Choose **File > New > Makefile Project with Existing Code**.
5. Click **Browse** next to **Existing Code Location**.
6. Browse to the **software/standalone/blinkAndEcho** directory and click **Select Folder**.
7. Select **<none>** in the **Toolchain for Indexer Settings** box.
8. Click **Finish**.

Import Project Settings (Optional)

易灵思 provides a C/C++ project settings file that defines the include paths and symbols for the C code. Importing these settings into your project lets you explore and jump through the code easily.



Note: You are not required to import the project settings to build. These settings simply make it easier for you to write and debug code.

To import the settings:

1. Choose **File > Import** to open the **Import** wizard.
2. Expand **C/C++**.
3. Choose **C/C++ > C/C++ Project Settings**.
4. Click **Next**.
5. Click **Browse** next to the **Settings file** box.

6. Browse to one of the following files and click **Open**:

Option	Description
Windows	embedded_sw\OpalT8\config\project_settings_opal.xml
Linux	embedded_sw\OpalT8/config_linux/project_settings_opal_linux.xml

7. In the **Select Project** box, select the project name(s) for which you want to import the settings.
8. Click **Finish**.

Eclipse creates a new folder in your project named **Includes**, which contains all of the files the project uses.

After you import the settings, clean your project (**Project > Clean**) and then build (**Project > Build Project**). The build process indexes all of the files so they are linked in your project.

Enable Debugging

When you set up your workspace, you defined an environment variable for debugging with a default value of **no**.

- To run the program for normal operation, keep **DEBUG** set to **no**.
- To debug with the OpenOCD debugger, set **DEBUG** to **yes**.

In debug mode, the program suspends operation after loading so that you can set breakpoints or perform debug tasks.

To change the debug settings for your project, right-click the project name **blinkAndEcho** in the Project Explorer and choose **Properties** from the pop-up menu.

1. Expand **C/C++ Build**.
2. Click **C/C++ Build > Environment**.
3. Click the **Debug** variable.
4. Click **Edit**.
5. Change the **Value** to **yes**.
6. Click **OK**.
7. Click **Apply and Close**.



Important: When you change the debug value for a project you previously built, you must clean the project (**Project > Clean**) before building again. Otherwise, Eclipse gives a message in the Console that there is Nothing to be done for 'all'

Build

Choose **Project > Build Project** or click the Build Project toolbar button.

The **makefile** builds the project and generates these files in the **build** directory:

- **blinkAndEcho.asm**—Assembly language file for the firmware.
- **blinkAndEcho.bin**—Download this file to the flash device on your board using OpenOCD. When you turn the board on, the SoC loads the application into the RISC-V processor and executes it.
- **blinkAndEcho.elf**—Use this file when debugging with the OpenOCD debugger.
- **blinkAndEcho.hex**—Hex file for the firmware. (Do not use it to program the FPGA.)
- **blinkAndEcho.map**—Contains the SoC address map.

Debug with the OpenOCD Debugger

Contents:

- [Import the Debug Configuration](#)
- [Debug](#)

With the development board programmed and the software built, you are ready to configure the OpenOCD debugger and perform debugging. These instructions use the **blinkAndEcho** example to explain the steps required.

The RTL design for the T8BGA81 Development Board uses a soft JTAG core instead of a hard JTAG TAP interface. Refer to [Connect the FTDI Chip Cable](#) on page 11 for instructions on connecting the C232HM-DDHSL-0 cable to this board.



Important: If you use the OpenOCD Debugger at the same time as the Efinity® Debugger, they conflict, causing one of the applications to crash.

Import the Debug Configuration

To simplify the debugging steps, the Opal SoC includes debug configurations that you import. There are several configuration files, depending on what functionality you want to use.

Table 3: Debug Configurations

Debug Configuration	Use for
default	Debugging software on Trion® development boards.
default_ti	Debugging software on 钛金系列 development boards.
default_softTap	Debugging software on Trion or 钛金系列 development boards with the soft JTAG TAP interface. For example, you would need to use the soft TAP if you want to use the OpenOCD debugger and the Efinity® Debugger at the same time. (See Using a Soft JTAG Core for Example Designs.)

To import a debug configuration and use it to launch a debug session:

1. Connect your board to your computer using a JTAG cable.
2. Launch Eclipse by running the **run_eclipse.bat** file (Windows) or **run_eclipse.sh** (Linux).
3. Select a workspace (if you have not set one as a default).
4. Open the **blinkAndEcho** project or select it under **C/C++ Projects**.
5. Right-click the **blinkAndEcho** project name and choose **Import**.
6. In the Import dialog box, choose **Run/Debug > Launch Configurations**.
7. Click **Next**. The Import Launch Configurations dialog box opens.

8. Browse to the following directory and click **OK**:

Option	Description
Windows	embedded_sw\OpalT8\config
Linux	embedded_sw/OpalT8/config_linux

9. Check the box next to **config** (Windows) or **config_linux** (Linux).
 10. Click **Finish**.
 11. Right-click the **blinkAndEcho** project name and choose **Debug As > Debug Configurations**.
 12. Choose **GDB OpenOCD Debugging > default_softTap**.



Note: Make sure to use the **default_softTap** debug configuration, not the **default** one. The **default_softTap** configuration targets the FTDI cable, while the **default** one targets the T20 BGA256 Development Board.

13. Enter **blinkAndEcho** in the **Project** box.
 14. Enter **build\blinkAndEcho.elf** in the **C/C++ Application** box.
 15. *Windows only:* you need to change the path to the **cpu0.yaml** file:
 - Click the **Debugger** tab.
 - In the **Config options** box, change `${workspace_loc}` to the full path to the **OpalT8** directory.



Note: For the **cpu0.yaml** path, make sure to use `\\` as the directory separator because the first slash escapes the second one. For example, use:
`c:\riscv\\OpalT8_devkit\\embedded_sw\\OpalT8\\cpu0.yaml`

16. Click **Debug**.



Note: If Eclipse prompts you to switch to the Debug Perspective, click **Switch**.

Debug

After you click **Debug** in the Debug Configuration window, the OpenOCD server starts, connects to the target, starts the gdb client, downloads the application, and starts the debugging session. Messages and a list of VexRiscv registers display in the **Console**. The **main.c** file opens so you can debug each step.

- Click the **Resume** button or press F8 to resume code operation. All of the LEDs on the board blink continuously in unison.
- Click **Step Over** (F6) to do a single step over one source instruction.
- Click **Step Into** (F5) to do a single step into the next function called.
- Click **Step Return** (F7) to do a single step out of the current function.
- Double-click in the bar to the left of the source code to set a breakpoint. Double-click a breakpoint to remove it.
- Click the **Registers** tab to inspect the processor's registers.
- Click the **Memory** tab to inspect the memory contents.
- Click the **Suspend** button to stop the code operation.
- When you finish debugging, click **Terminate** to disconnect the OpenOCD debugger.

The **blinkAndEcho** example blinks the LEDs and prints messages on a UART terminal. Refer to [Using a UART Module](#) on page 34 for steps on setting it up.

Figure 4: Perform Debugging

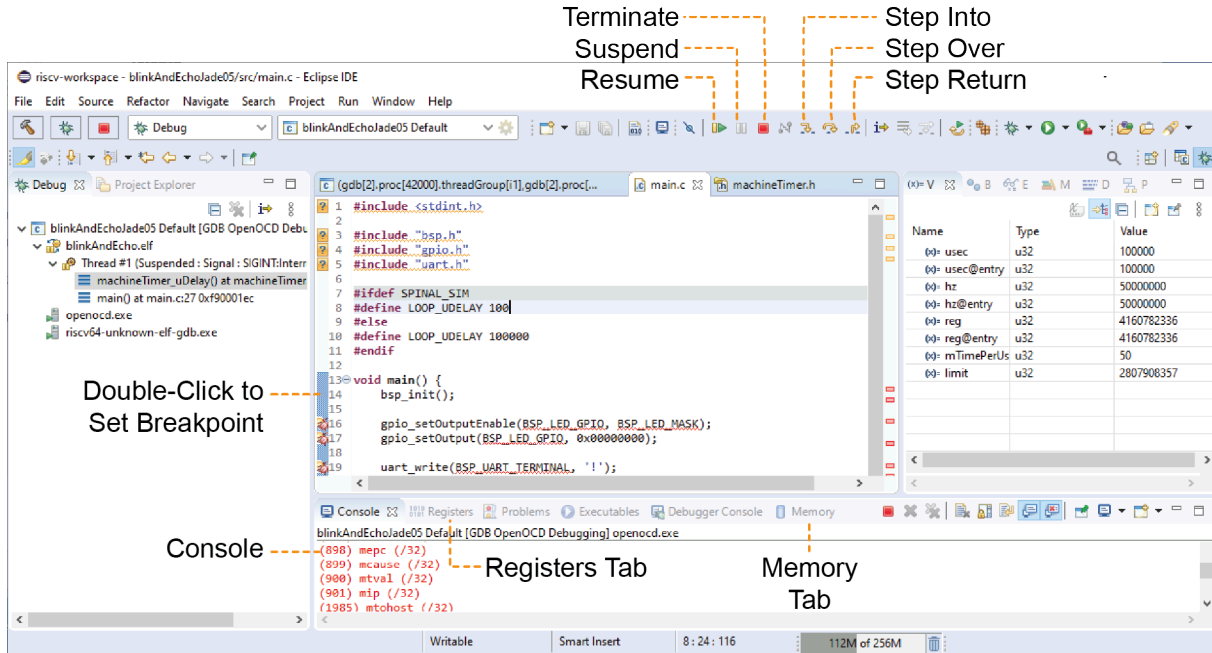

Learn more: For more information on debugging with Eclipse, refer to [Running and debugging projects](#) in the Eclipse documentation.

Create Your Own RTL Design

Contents:

- [Create a Custom APB3 Peripheral](#)
- [Remove Unused Peripherals from the RTL Design](#)
- [Target Your Own Board](#)

After you have explored the Opal SoC using this example project, you can use these tips to modify the design for your own use. 易灵思 recommends that you use the provided example design project as a starting point instead of creating a new project.



Note: Because the project targets the T8 FPGA and the Trion® T8 BGA81 Development Board, if you want to use another 易灵思 board or FPGA, it is easier to start fresh with the IP Manager and a new SoC instance.

Create a Custom APB3 Peripheral

When you generate an example design for the Opal SoC, the IP Manager creates an APB3 peripheral and software code that you can use as a template to create your own peripheral. This simple example shows how to implement an APB3 slave wrapper.

- Refer to `apb3_slave.v` in the `T8F81_devkit` directory for the RTL design.
- Refer to `main.c` in the `embedded_sw/OpalT8/software/standalone/EfxApb3Example/src` directory for the C code.

Remove Unused Peripherals from the RTL Design

The Opal SoC includes a variety of peripherals. If you do not want to use a peripheral, simply remove the signal name from within the parentheses () in the OpalSoc OpalSoc_inst definition in the top-level Verilog HDL file. For example, the SoC instantiation has these signals:

```
.system_i2c_0_io_sda_write      (system_i2c_0_io_sda_write),
.system_i2c_0_io_sda_read      (system_i2c_0_io_sda_read),
.system_i2c_0_io_scl_write     (system_i2c_0_io_scl_write),
.system_i2c_0_io_scl_read      (system_i2c_0_io_scl_read),
```

To disable I²C 0, remove the signal name in () as shown below:

```
.system_i2c_0_io_sda_write      (),
.system_i2c_0_io_sda_read      (),
.system_i2c_0_io_scl_write     (),
.system_i2c_0_io_scl_read      (),
```

Target Your Own Board

Generally, when debugging your own board you use a JTAG cable to connect your computer and the board. The BSP includes OpenOCD configuration files that target the FTDI C232HM-DDHSL-0 JTAG cable. These files are located in the **bsp/efinix/EfxOpalSoc/openocd** directory. If you create your own board using the T8 FPGA, you can use the provided configuration files. Additionally, OpenOCD includes a number of configuration files for standard hardware products. These files are located in the following directory:

openocd/build-win64/share/openocd/scripts/interface (Windows)

openocd/build-x86_64/share/openocd/scripts/interface (Linux)

You can also write your own configuration file if desired.

Follow these instructions when debugging with your own board:

1. Connect your JTAG cable to the board and to your computer.
2. Copy the OpenOCD configuration file for your cable to the **bsp/efinix/EfxOpalSoc/openocd** directory.
3. Follow the instructions for debugging, except target your configuration file.

```
-f <path>/bsp/efinix/EfxOpalSoc/openocd/<my_cable>.cfg
```

Create Your Own Software

Contents:

- [Deploying an Application Binary](#)
- [About the Board Specific Package](#)
- [Address Map](#)
- [Example Software](#)

Now that you have explored the methodology for designing with the Opal SoC, you can develop your own software applications.



Note: The Opal SoC does not currently support floating point calculations, such as sine and cosine.

Deploying an Application Binary

For debugging, you can load the user binary (**.elf**) directly into the Opal SoC using the OpenOCD Debugger. After loading, the binary executes immediately.



Note: The settings in the linker prevent user access to the address. This setting allows the embedded bootloader to work properly during a system reset after the user binary is executed but the FPGA is not reconfigured.

Boot from a Flash Device

When the FPGA boots up, the Opal SoC copies your binary application file from a SPI flash device to the on-chip memory, and then begins execution. For the T8 BGA81 Development Board and Xyloni Development Board, the SPI flash binary address starts at 0x000E_0000.

To boot from a SPI flash device:

1. Power up your board. The FPGA loads the configuration image from the on-board flash device.
2. When configuration completes, the bootloader begins cloning a 4 KByte user binary file from the flash device at physical address 0x000E_0000 to the on-chip memory.



Note: It takes ~10 ms to clone a 4 KByte user binary (this is the default size).

3. The Opal SoC executes the user binary.

Boot from the OpenOCD Debugger

To boot from the OpenOCD debugger:

1. Power up your board. The FPGA loads the configuration image from the on-board flash device.
2. Launch Eclipse and set up the debug environment for your project.
3. When you click **Debug**, the debugger sends a soft reset to the SoC, and then writes the user binary file to logical address 0xF900_0000, which is the starting address of the on-chip memory.
4. The Opal SoC jumps to logical address 0xF900_0000 to execute the user binary.
5. The user binary is suspended on boot up. Click the Resume button to start the program.



Note: Refer to [Debug with the OpenOCD Debugger](#) on page 21 for complete instructions on debugging.

Copy a User Binary to the Flash Device

To boot from a flash device, you need to copy the binary to the device. These instructions describe how to use a command prompt or shell to flash the user binary file. You use two command prompts or shells:

- The first terminal opens an OpenOCD connection to the SoC.
- The second connects to the first terminal to write to the flash.



Important: If you are using the OpenOCD debugger in Eclipse, terminate any debug processes before attempting to flash the memory.

Set Up Terminal 1

1. Open a Windows command prompt or Linux shell.
2. Change to **SDK_Windows** or **SDK_Ubuntu**.
3. Execute the **setup.bat** (Windows) or **setup.sh** (Linux) script.
4. Change to the directory that has the **cpu0.yaml** file.
5. Type the following commands to set up the OpenOCD server:

Windows:

```
openocd.exe -f bsp\efinix\EfxSoc\openocd\ftdi.cfg
-c "set CPU0_YAML cpu0.yaml"
-f bsp\efinix\EfxSoc\openocd\flash.cfg
```

Linux:

```
openocd -f bsp/efinix/EfxSoc/openocd/ftdi.cfg
-c "set CPU0_YAML cpu0.yaml"
-f bsp/efinix/EfxSoc/openocd/flash.cfg
```

The OpenOCD server connects and begins listening on port 4444.

Set Up Terminal 2

1. Open a second command prompt or shell.
2. Enable telnet if it is not turned on. [Turn on telnet \(Windows\)](#)
3. Open a telnet local host on port 4444 with the command `telnet localhost 4444`.

4. In the OpenOCD shell or command prompt, use the following command to flash the user binary file:

```
flash write_image erase unlock <path>/<filename>.bin 0xe0000
```

Where *<path>* is the full, absolute path to the **.bin** file.



Note: For Windows, use \\ as the directory separators.

Close Terminals

When you finish:

- Type `exit` in terminal 2 to close the telnet session.
- Type `Ctrl+C` in terminal 1 to close the OpenOCD session.



Important: OpenOCD cannot be running in Eclipse when you are using it in a terminal. If you try to run both at the same time, the application will crash or hang. Always close the terminals when you are done flashing the binary.

Reset the FPGA

Press the reset button (SW1) on the development board.

About the Board Specific Package

The board specific package (BSP) defines the address map and aligns with the Opal SoC hardware address map. The BSP files are located in the **bsp/efinix/EfxOpalSoC** subdirectory.

Table 4: BSP Files

File or Directory	Description
app	Files used by the example software and bootloader.
include\soc.mk	Supported instruction set.
include\soc.h	Defines the system frequency and address map.
linker\default.ld	Linker script for the main memory address and size.
linker\bootloader.ld	Linker script for the bootloader address and size.
openocd	OpenOCD configuration files.

Address Map



Note: Because the address range might be updated, 易灵思 recommends that you always refer to the parameter name when referencing an address in firmware, not by the actual address. The parameter names and address mappings are defined in **soc.h**.

Table 5: Default Address Map, Interrupt ID, and Cached Channels

Device	Parameter	Size	Interrupt ID	Region
GPIO	SYSTEM_GPIO_0_IO_APB	4K	[0]: 12 [1]: 13	I/O
I ² C	SYSTEM_I2C_0_IO_APB	4K	8	I/O
Machine timer	SYSTEM_MACHINE_TIMER_APB	4K	31	I/O
PLIC	SYSTEM_PLIC_APB	4K	-	I/O
SPI master	SYSTEM_SPI_0_IO_APB	4K	4	I/O
UART	SYSTEM_UART_0_IO_APB	4K	1	I/O
User peripheral	IO_APB_SLAVE_0_APB	64K	-	I/O
On-chip BRAM	SYSTEM_RAM_A_BMB	512 KB	-	Cache
External interrupt	-	-	25	I/O



Note: The RISC-V GCC compiler does not support user address spaces starting at 0x0000_0000.

Example Software

To help you get started writing software for the Opal, 易灵思 provides a variety of example software code that performs functions such as communicating through the UART, controlling GPIO interrupts, performing Dhrystone benchmarking, etc. Each example includes a **makefile** and **src** directory that contains the source code.



Note: Many of these examples display messages on a UART. Refer to the following topics for information on attaching a UART module and connecting to it in a terminal:

[Learn how to attach a UART module.](#)

[Learn how to open an Eclipse terminal and connect to the UART module.](#)

Table 6: Example Software Code

Directory	Description
blinkAndEcho	This example blinks an LED and prints a string on the UART terminal.
bootloader	This software is the bootloader for the system.
common	Provides linking for the makefiles.
driver	This directory contains the system drivers for the peripherals (I ² C, UART, SPI, etc.). Refer to API Reference on page 40 for details.
EfxApb3Example	This example shows how to implement an APB3 slave.
i2cDemo	This example shows how to connect to an MCP4725 digital-to-analog converter (DAC) using an I ² C peripheral.
readFlash	This example shows how to read from a SPI flash device.
spiDemo	This code reads the device ID and JEDEC ID of a SPI flash device and echoes the characters on a UART.
timerAndGpioInterruptDemo	This example shows how to use use interrupts with a timer and GPIO.
userInterruptDemo	This example demonstrates user interrupts with UART messages.
uartInterruptDemo	This exmple shows how to use a UART interrupt.
writeFlash	This example shows how to write to a SPI flash device.

blinkAndEcho Example

The blink and echo example (**blinkAndEcho** directory) is a simple example that shows how to use a register pointer to output data for the GPIO and UART. The design blinks LEDs D5 and D6 on the T8 BGA81 Development board. When you type a character, it echoes it on a UART terminal.

EfxApb3Example

This simple software design illustrates how to use an APB3 slave peripheral.

The APB3 slave is attached to a pseudorandom number generator. When you run the application, the Opal SoC programs the APB3 slave to stop generating a new random number and reads the last random number generated. The test passes if the returned data is a non-zero value.

```
APB0 test
Random number: 0xE1ECA84A
Passed!
```

When you run the application, it blinks LEDs D2 and D3 and displays messages on a UART terminal.

i2cDemo Example

The I²C interrupt example (**i2cDemo** directory) provides example code for an I²C master writing data to and reading data from an off-chip MCP4725 device with interrupt. The Microchip MCP4725 device is a single channel, 12-bit, voltage output digital-to-analog converter (DAC) with an I²C interface.

The MCP4725 device is available on breakout boards from vendors such as Adafruit and SparkFun. You can connect the breakout board's SDA and SCL pins to a development board.

Trion[®] T8 BGA81 Development Board:

- SCL—GPIOR_21, which is labeled as 21 on header J5
- SDA—GPIOR_30, which is labeled as 30 on header J5

The code assumes that the I²C block is the only master on the bus, and it sends frames in blocks. When you run it, the application connects to the MCP4725 device and increases the DAC value. It also prints the message `Start` on a UART terminal.

In this example:

- `void trap()` traps entries on exceptions and interrupt events
- `void externalInterrupt()` triggers an interrupt event

readFlash Example

The read flash example (**readFlash** directory) shows how to read data from the SPI flash device on the development board. The software reads 124K of data starting at address `0xe0000`, which is the default location of the user binary in the flash device. The application displays messages on a UART terminal:

```
Read Flash Start
Addr 00380000 : =FF
Addr 00380001 : =FF
Addr 00380002 : =FF
...
Addr 0039EFFF : =FF
Addr 0039EFFF : =FF
Read Flash End
```

spiDemo Example

The SPI example (**spiDemo** directory) provides example code for reading the device ID and JEDEC ID of the SPI flash device on the development board.

- The default base address map of the SPI flash master is 0xF801_4000.
- The default SCK frequency is half of the SoC system clock frequency.
- The default base address of the UART is 0xF801_0000 with a default baud rate of 115200.

The application displays the results on a UART terminal. It continues to print to the terminal until you suspend or stop the application.

```
Hello world
Device ID : 17
CMD 0x9F : EF4018
CMD 0x9F : EF4018
...
```

timerAndGpioInterruptDemo Example

The GPIO interrupt example (**timerAndGpioInterruptDemo** directory) provides example code for implementing a rising edge interrupt trigger with a GPIO pin. When an interrupt occurs, a UART terminal displays Hello world and then the timer interval. It continues to print the timer interval until you suspend or stop the application.

```
Hello world
BSP_MACHINE_TIMER 0
BSP_MACHINE_TIMER 1
...
```

In this example:

- void trap() traps entries on exceptions and interrupt events
- void externalInterrupt() triggers a GPIO interrupt event

UartInterruptDemo Example

The UartInterruptDemo example shows how to use a UART interrupt to indicate task completion when sending or receiving data over a UART. The UART can trigger an interrupt when data is available in the UART receiver FIFO or when the UART transmitter FIFO is empty. In this example, when you type a character in a UART terminal, the data goes to the UART receiver and fills up FIFO buffer. This action interrupts the processor and forces the processor to execute an interrupt/priority routine that allows the UART to read from the buffer and send a message back to the terminal.

The application displays messages on a UART terminal:

```
RX FIFO not empty interrupt
RX FIFO not empty interrupt
RX FIFO not empty interrupt
```

userInterruptDemo Example

The user interrupt example (**userInterruptDemo** directory) uses one bit from an APB3 slave peripheral as an interrupt signal to RISC-V processor. The main routine sets up an interrupt routine, then triggers an interrupt signal to the user interrupt port by programming bit 2 on the APB3 slave to high.

When the RISC-V processor receives the interrupt signal, program execution jumps from the main routine to the interrupt (or priority) routine. The interrupt routine sets bit 2 low so the processor can leave the interrupt routine.

The application displays the messages on a UART terminal:

```
User Interrupt Demo, waiting for user interrupt...
Entered User Interrupt Routine
Turn off Interrupt Signal
Leaving User Interrupt Routine
```

writeFlash Example

The read flash example (**writeFlash** directory) shows how to write data to the SPI flash device on the development board. The software writes data starting at address 0xe0000, which is the default location of the user binary in the flash device. The application displays address and data messages on a UART terminal:

```
Write Flash Start
WR Addr 00380000 : =00
WR Addr 00380001 : =01
WR Addr 00380002 : =02
...
WR Addr 003800FD : =FD
WR Addr 003800FE : =FE
WR Addr 003800FF : =FF
Write Flash End
```

Using a UART Module

Contents:

- [Set Up a USB-to-UART Module \(Trion\)](#)
- [Open a Terminal](#)
- [Enable Telnet on Windows](#)

Set Up a USB-to-UART Module (Trion)

A number of the software examples display messages on a UART terminal. The Trion® T8 BGA81 Development Board does not have a USB-to-UART converter, therefore, you need to use a separate USB-to-UART converter module. A number of modules are available from various vendors; any USB-to-UART module should work.

Connect to the T8 BGA81 Development Board

Figure 5: Connect the UART Module to I/O Header J5

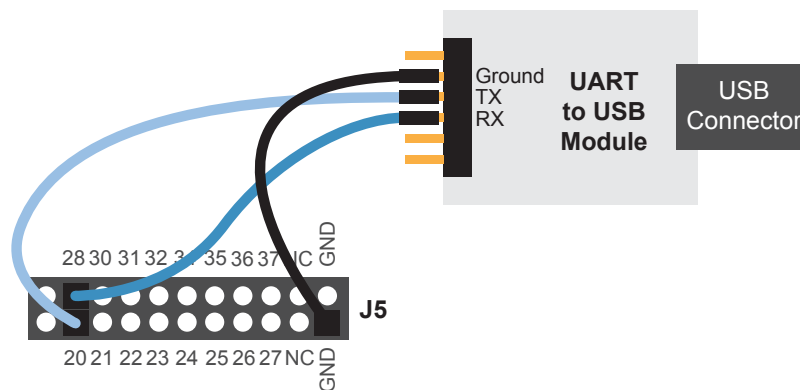

1. Connect the UART's RX, TX, and ground pins to the T8 BGA81 Development Board using:
 - *RX*—GPIOR_28, which is labeled as 28 on header J5
 - *TX*—GPIOR_20, which is labeled as 20 on header J5
 - *Ground*—Ground, connect to one of the GND pins on header J5
2. Plug the UART module into a USB port on your computer. The driver should install automatically if needed.

Finding the COM Port (Windows)

1. Type Device Manager in the Windows search box.
2. Expand **Ports (COM & LPT)** to find out which COM port Windows assigned to the UART module; it is listed as USB Serial Port (COM n) where n is the assigned port number. Note the COM number.

Finding the COM Port (Linux)

In a terminal, type the command:

```
dmesg | grep ttyUSB
```

The terminal displays a series of messages about the attached devices.

```
usb <number>: <adapter> now attached to ttyUSB<number>
```

There are many USB-to-UART converter modules on the market. Some use an FTDI chip which displays a message similar to:

```
usb 3-3: FTDI USB Serial Device converter now attached to ttyUSB0
```

Open a Terminal

You can use any terminal program, such as Putty, termite, or the built-in Eclipse terminal, to connect to the UART. These instructions explain how to use the Eclipse terminal; the others are similar.

1. In Eclipse, choose **Window > Show View > Terminal**. The Terminal tab opens.

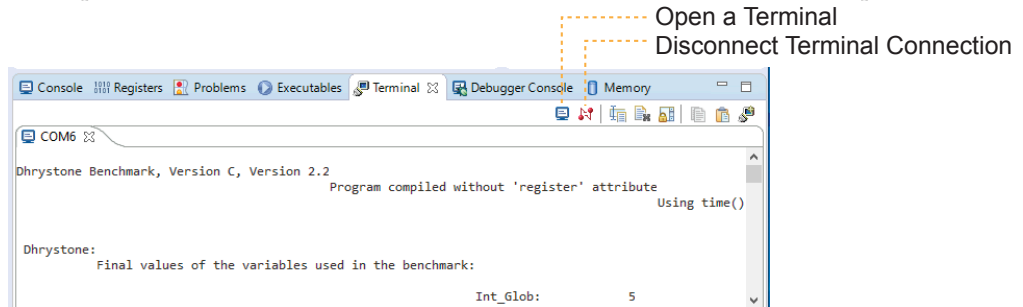

2. Click the Open a Terminal button.
3. In the **Launch Terminal** dialog box, enter these settings:

Option	Setting
Choose terminal	Serial Terminal
Serial port	COM n (Windows) or ttyUSB n (Linux) where n is the port number for your UART module.
Baud rate	115200
Data size	8
Parity	None
Stop bits	1
Encoding	Default (ISO-8859-1)

4. Click **OK**. The terminal opens a connection to the UART.
5. Run your application. Messages are printed in the terminal.
6. When you are finished using the application, click the Disconnect Terminal Connection button.

Enable Telnet on Windows

Windows does not have telnet turned on by default. Follow these instructions to enable it:

1. Type `telnet` in the Windows search box.
2. Click **Turn Windows features on or off (Control panel)**. The **Windows Features** dialog box opens.
3. Scroll down to **Telnet Client** and click the checkbox.
4. Click **OK**. Windows enables telnet.
5. Click **Close**.

Troubleshooting

Contents:

- [Error 0x80010135: Path too long \(Windows\)](#)
- [OpenOCD Error: timed out while waiting for target halted](#)
- [OpenOCD error code \(-1073741515\)](#)
- [OpenOCD Error: no device found](#)
- [OpenOCD Error: failed to reset FTDI device: LIBUSB_ERROR_IO](#)
- [OpenOCD Error: target 'fpga_spinal.cpu0' init failed](#)
- [Eclipse Fails to Launch with Exit Code 13](#)
- [Efinity Debugger Crashes when using OpenOCD](#)
- [Undefined Reference to 'cosf'](#)

Error 0x80010135: Path too long (Windows)

When you unzip the SDK on Windows, you may get the error message:

```
An unexpected error is keeping you from copying the file. If you continue to receive this error, you can use the error code to search for help with this problem.
```

```
Error 0x80010135: Path too long
```

This error occurs if you try to unzip the SDK files into a deep folder hierarchy instead of one that is close to the root level. Instead unzip to **c:\riscv-sdk**.

OpenOCD Error: timed out while waiting for target halted

The OpenOCD debugger console may display this error when:

- There is a bad contact between the FPGA header pins and the programming cable.
- The FPGA is not configured with a Opal SoC design.
- You may not have the correct PLL settings to work with the Opal SoC.
- Your computer does not have enough memory to run the program.

To solve this problem:

- Make sure that all of the cables are securely connected to the board and your computer.
- Check the JTAG connection.
- Ensure that the FPGA is programmed with the Opal SoC. Refer to [Program the Development Board](#) on page 12.

OpenOCD error code (-1073741515)

The OpenOCD debugger may fail with error code -1073741515 if your system does not have the **libusb0.dll** installed. To fix this problem, install the DLL. This issue only affects Windows systems.

OpenOCD Error: no device found

The FTDI driver included with the Opal SoC specifies the FTDI device VID and PID, and board description. In some cases, an early revision of the 易灵思 development board may have a different name than the one given in the driver file. If the board name does not match the name in the driver, OpenOCD will fail with an error similar to the following:

```
Error: no device found
Error: unable to open ftdi device with vid 0403, pid 6010, description 'Trion T20 Development Board', serial '*' at bus location '*'
```

To fix this problem, follow these steps with the development board attached to the computer:

1. Open the Efinity Programmer.
2. Click the **Refresh USB Targets** button to display the board name in the **USB Target** drop-down list.
3. Make note of the board name.
4. In a text editor, open the **ftdi.cfg** (Trion) or **ftdi_ti.cfg** (钛金系列) file in the **/bsp/efinix/EFXOpalSoC/openocd** directory.
5. Change the `ftdi_device_desc` setting to match your board name. For example, use this code to change the name from Trion T20 Development Board to Trion T20 Developer Board:

```
interface ftdi
ftdi_device_desc "Trion T20 Developer Board"
#ftdi_device_desc "Trion T20 Development Board"
ftdi_vid_pid 0x0403 0x6010
```

6. Save the file.
7. Debug as usual in OpenOCD.

OpenOCD Error: failed to reset FTDI device: LIBUSB_ERROR_IO

This error is typically caused because you have the wrong Windows USB driver for the development board. If you have the wrong driver, you will get an error similar to:

```
Error: failed to reset FTDI device: LIBUSB_ERROR_IO
Error: unable to open ftdi device with vid 0403, pid 6010, description 'Trion T20 Development Board', serial '*' at bus location '*'
```



Important: 易灵思 recommends using the **libusbK** driver, which you install using the Zadig software. Refer to [Install USB Drivers](#) on page 11

OpenOCD Error: target 'fpga_spinal.cpu0' init failed

You may receive this error when trying to debug after creating your OpenOCD debug configuration. The Eclipse Console gives an error message similar to:

```
Error cpuConfigFile C:\RiscVsoc_Jadesoc_jade_swcpu0.yaml not found
Error: target 'fpga_spinal.cpu0' init failed
```

This error occurs because the path to the **cpu0.yaml** file is incorrect, specifically the slashes for the directory separators. You should use:

- a single forward slash (/)
- 2 backslashes (\)

For example, either of the following are good:

```
C:\\RiscV\\soc_Jade\\soc_jade_sw\\cpu0.yaml
C:/RiscV/soc_Jade/soc_jade_sw/cpu0.yaml
```

Eclipse Fails to Launch with Exit Code 13

The Eclipse software requires a 64-bit version of the Java JRE. If you use a 32-bit version, when you try to launch Eclipse you will get an error that Java quit with exit code 13.

If you are downloading the JRE using a web browser from www.java.com, it defaults to getting the 32-bit version. Instead, go to <https://www.java.com/en/download/manual.jsp> to download the 64-bit version.

Efinity® Debugger Crashes when using OpenOCD

The Efinity® Debugger crashes if you try to use it for debugging while also using OpenOCD. Both applications use the same USB connection to the development board, and conflict if you use them at the same time. To avoid this issue, do not use the two debuggers at the same time.

Undefined Reference to 'cosf'

You may receive an error similar to this when using calculating square root, sine, or cosine with floating-point numbers in your application. The Opal SoC does not currently support floating point.

API Reference

Contents:

- [Control and Status Registers](#)
- [GPIO API Calls](#)
- [I2C API Calls](#)
- [I/O API Calls](#)
- [Machine Timer API Calls](#)
- [PLIC API Calls](#)
- [SPI API Calls](#)
- [SPI Flash Memory API Calls](#)
- [UART API Calls](#)
- [Handling Interrupts](#)

The following sections describe the API for the code in the **driver** directory.

Control and Status Registers

csr_clear()

Usage	<code>csr_clear(csr, val)</code>
Include	driver/riscv.h
Description	Clear a CSR.

csr_read()

Usage	<code>csr_read(csr)</code>
Include	driver/riscv.h
Description	Read from a CSR.
Example	<code>csrr (t0, mepc) // Write mepc in regfile[t0]</code>

csr_read_clear()

Usage	<code>csr_read_clear(csr, val)</code>
Include	driver/riscv.h
Description	CSR read and clear bit.

csr_read_set()

Usage	<code>csr_read_set(csr, val)</code>
Include	driver/riscv.h
Description	CSR read and set bit.

csr_set()

Usage	<code>csr_set(csr, val)</code>
Include	driver/riscv.h
Description	CSR set bit.

csr_swap()

Usage	<code>csr_write(csr, val)</code>
Include	driver/riscv.h
Description	Swaps values in the CSR.

csr_write()

Usage	<code>csr_write(csr, val)</code>
Include	driver/riscv.h
Description	Write to a CSR.
Example	<code>csrw (mepc, t0); // Write regfile[t0] in mepc</code>

GPIO API Calls

gpio_getFilteringHit()

Usage	<code>gpio_getFilteringHit(reg)</code>
Parameters	[IN] reg struct of I ² C setting value
Include	driver/i2c.h
Description	Read the 32-bit I ² C register filter hit with a call back function.
Example	<pre>if(gpio_getFilteringHit(I2C_CTRL) == 1) // Check filter hit value, bit [7] from slave address, // read ='1' write ='0'</pre>

gpio_getFilteringStatus()

Usage	<code>gpio_getFilteringStatus(reg)</code>
Parameters	[IN] reg struct of I ² C setting value
Include	driver/i2c.h
Description	Read the 32-bit I ² C register filter hit with a call back function.
Example	<pre>if(gpio_getFilteringStatus (I2C_CTRL) == 1) // Check filter hit status, bit [7] from slave address, read ='1' write ='0'</pre>

gpio_getInput()

Usage	gpio_getInput (GPIO_Reg, value)
Parameters	[IN] GPIO_Reg struct of GPIO register [IN] value GPIO pin bitwise
Include	driver/gpio.h
Description	Get input from a GPIO.

gpio_getInterruptFlag()

Usage	gpio_getInterruptFlag (reg)
Parameters	[IN] reg struct of I ² C setting value
Include	driver/i2c.h
Description	Read the 32-bit I ² C register interrupt flag with a call back function.
Example	<pre> int flag = gpio_getInterruptFlag(I2C_CTRL) & I2C_INTERRUPT_DROP; // Get Drop interrupt flag from Interrupt register //[2] I2C_INTERRUPT_TX_DATA //[3] I2C_INTERRUPT_TX_ACK //[7] I2C_INTERRUPT_DROP //[16] I2C_INTERRUPT_CLOCK_GEN_BUSY //[17] I2C_INTERRUPT_FILTER </pre>

gpio_getMasterStatus()

Usage	gpio_getMasterStatus (reg)
Parameters	[IN] reg struct of I ² C setting value
Include	driver/i2c.h
Description	Read the 32-bit I ² C register master status with a call back function.
Example	<pre> int status = gpio_getMasterStatus(I2C_CTRL) & I2C_MASTER_BUSY; // Get master busy status from status register [0] I2C_MASTER_BUSY [4] I2C_MASTER_START [5] I2C_MASTER_STOP [6] I2C_MASTER_DROP </pre>

gpio_getOutput()

Usage	gpio_getOutput (GPIO_Reg, value)
Parameters	[IN] GPIO_Reg struct of GPIO register [IN] value GPIO pin bitwise
Include	driver/gpio.h
Description	Read the output pin.

gpio_getOutputEnable()

Usage	<code>gpio_getOutputEnable(GPIO_Reg, value)</code>
Parameters	[IN] GPIO_Reg struct of GPIO register [IN] value GPIO pin bitwise
Include	driver/gpio.h
Description	Read GPIO output enable.

gpio_setOutput()

Usage	<code>gpio_setOutput(GPIO_Reg, value)</code>
Parameters	[IN] GPIO_Reg struct of GPIO register [IN] value GPIO pin bitwise
Include	driver/gpio.h
Description	Set GPIO as 1 or 0.

gpio_setOutputEnable()

Usage	<code>gpio_setOutputEnable(GPIO_Reg, value)</code>
Parameters	[IN] GPIO_Reg struct of GPIO register [IN] value GPIO pin bitwise
Include	driver/gpio.h
Description	Set GPIO as an output enable.

gpio_setInterruptRiseEnable()

Usage	<code>gpio_etInterruptRiseEnable(GPIO_Reg, value)</code>
Parameters	[IN] GPIO_Reg struct of GPIO register [IN] value GPIO pin bitwise
Include	driver/gpio.h
Description	Set an interrupt on the rising edge of the GPIO.

gpio_setInterruptFallEnable()

Usage	<code>gpio_setInterruptFallEnable(GPIO_Reg, value)</code>
Parameters	[IN] GPIO_Reg struct of GPIO register [IN] value GPIO pin bitwise
Include	driver/gpio.h
Description	Set an interrupt on the falling edge of the GPIO.

gpio_setInterruptHighEnable()

Usage	<code>gpio_setInterruptHighEnable(GPIO_Reg, value)</code>
Parameters	[IN] GPIO_Reg struct of GPIO register [IN] value GPIO pin bitwise
Include	driver/gpio.h
Description	Set an interrupt when the GPIO is high.

gpio_setInterruptLowEnable()

Usage	<code>gpio_setInterruptLowEnable(GPIO_Reg, value)</code>
Parameters	[IN] GPIO_Reg struct of GPIO register [IN] value GPIO pin bitwise
Include	driver/gpio.h
Description	Set an interrupt when the GPIO is low.

I²C API Calls

i2c_applyConfig()

Usage	<code>void i2c_applyConfig(u32 reg, I2c_Config *config)</code>
Parameters	[IN] reg struct of I ² C setting value [IN] config struct of I ² C configuration
Include	driver/i2c.h
Description	Apply I ² C configuration to register or for initial configuration.

i2c_clearInterruptFlag()

Usage	<code>void i2c_clearInterruptFlag(u32 reg, u32 value)</code>
Parameters	[IN] reg struct of I ² C setting value [IN] value I ² C interrupt register
Include	driver/i2c.h
Description	Clear the I ² C interrupt flag.

i2c_disableInterrupt()

Usage	<code>void i2c_disableInterrupt(u32 reg, u32 value)</code>
Parameters	[IN] reg struct of I ² C setting value [IN] value I ² C interrupt register: <ul style="list-style-type: none"> • [2] I2C_INTERRUPT_TX_DATA • [3] I2C_INTERRUPT_TX_ACK • [7] I2C_INTERRUPT_DROP • [16] I2C_INTERRUPT_CLOCK_GEN_BUSY • [17] I2C_INTERRUPT_FILTER
Include	driver/i2c.h
Description	Disable I ² C interrupt.
Example	<pre>i2c_disableInterrupt(I2C_CTRL, I2C_INTERRUPT_TX_ACK); // Enable I2C interrupt with interrupt TX ACK</pre>

i2c_enableInterrupt()

Usage	<code>void i2c_enableInterrupt(u32 reg, u32 value)</code>
Parameters	[IN] <code>reg</code> struct of I ² C setting value [IN] <code>value</code> I ² C interrupt register: <ul style="list-style-type: none"> • [2] I2C_INTERRUPT_TX_DATA • [3] I2C_INTERRUPT_TX_ACK • [7] I2C_INTERRUPT_DROP • [16] I2C_INTERRUPT_CLOCK_GEN_BUSY • [17] I2C_INTERRUPT_FILTER
Include	driver/i2c.h
Description	Enable I ² C interrupt.
Example	<pre>i2c_enableInterrupt(I2C_CTRL, I2C_INTERRUPT_FILTER I2C_INTERRUPT_DROP); // Enable I2C interrupt with interrupt filter and drop</pre>

i2c_filterEnable()

Usage	<code>void i2c_filterEnable(u32 reg, u32 filterId, u32 config)</code>
Parameters	[IN] <code>reg</code> struct of I ² C setting value [IN] <code>filterID</code> filter configuration ID number [IN] <code>config</code> struct of I ² C configuration
Include	driver/i2c.h
Description	Enable the filter configuration.

i2c_listenAck()

Usage	<code>void i2c_listenAck(u32 reg)</code>
Parameters	[IN] <code>reg</code> struct of I ² C register
Include	driver/i2c.h
Description	Listen acknowledge from the slave.

i2c_masterBusy()

Usage	<code>void i2c_masterBusy(u32 reg)</code>
Parameters	[IN] <code>reg</code> struct of I ² C register
Include	driver/i2c.h
Description	Get the I ² C busy status.

i2c_masterDrop()

Usage	<code>void i2c_masterDrop(u32 reg)</code>
Parameters	[IN] <code>reg</code> struct of I ² C register
Include	driver/i2c.h
Description	Change the I ² C master to the drop state.
Example	<code>i2c_masterDrop(I2C_CTRL);</code>

i2c_masterStart()

Usage	<code>void i2c_masterStart(u32 reg)</code>
Parameters	[IN] reg struct of I ² C register
Include	driver/i2c.h
Description	Change the I ² C master to the start status.

i2c_masterStartBlocking()

Usage	<code>void i2c_masterStartBlocking(u32 reg)</code>
Parameters	[IN] reg struct of I ² C register
Include	driver/i2c.h
Description	Asserts a start condition.

i2c_masterStop()

Usage	<code>void i2c_masterStop(u32 reg)</code>
Parameters	[IN] reg struct of I ² C register
Include	driver/i2c.h
Description	Change the I ² C master to the stop status.

i2c_masterStopBlocking()

Usage	<code>void i2c_masterStartBlocking(u32 reg)</code>
Parameters	[IN] reg struct of I ² C register
Include	driver/i2c.h
Description	Asserts a stop condition.

i2c_masterStopWait()

Usage	<code>void i2c_masterStopWait(u32 reg)</code>
Parameters	[IN] reg struct of I ² C register
Include	driver/i2c.h
Description	The stop condition is wait busy..

i2c_setFilterConfig()

Usage	<code>void i2c_setFilterConfig(u32 reg, u32 filterId, u32 config)</code>
Parameters	<p>[IN] <code>reg</code> struct of I²C setting value</p> <p>[IN] <code>filterID</code> filter configuration ID number</p> <p>[IN] <code>config</code> struct of I²C configuration:</p> <ul style="list-style-type: none"> • [9:0] I2C slave address • [14] I2C_FILTER_10BITS • [15] I2C_FILTER_ENABLE
Include	driver/i2c.h
Description	Set the filter configuration.
Example	<pre>i2c_setFilterConfig(I2C_CTRL, 0, 0x30 I2C_FILTER_ENABLE); // Enable filter with ID=0 slave addr = 0x30 default 7 bit filter</pre>

i2c_txAck()

Usage	<code>void i2c_txAck(u32 reg)</code>
Parameters	[IN] <code>reg</code> struct of I ² C register
Include	driver/i2c.h
Description	Transmit acknowledge.

i2c_txAckBlocking()

Usage	<code>void i2c_txAckBlocking(u32 reg)</code>
Parameters	[IN] <code>reg</code> struct of I ² C register
Include	driver/i2c.h
Description	Assert an ACK on the SDA pin.

i2c_txAckWait()

Usage	<code>void i2c_txAckWait(u32 reg)</code>
Parameters	[IN] <code>reg</code> struct of I ² C register
Include	driver/i2c.h
Description	Wait for an acknowledge to transmit.

i2c_txByte()

Usage	<code>void i2c_txByte(u32 reg, u8 byte)</code>
Parameters	<p>[IN] <code>reg</code> struct of I²C register</p> <p>[IN] <code>byte</code> 8 bits data to send out</p>
Include	driver/i2c.h
Description	Transfers one byte to the I ² C slave.

i2c_txByteRepeat()

Usage	<code>void i2c_txByteRepeat(u32 reg, u8 byte)</code>
Parameters	[IN] <code>reg</code> struct of I ² C register [IN] <code>byte</code> 8 bits data to send out
Include	driver/i2c.h
Description	Send a byte and then wait until it is fully transmitted on the I ² C bus.

i2c_txNack()

Usage	<code>void i2c_txNack(u32 reg)</code>
Parameters	[IN] <code>reg</code> struct of I ² C register
Include	driver/i2c.h
Description	Transfers a NACK.

i2c_txNackRepeat()

Usage	<code>void i2c_txNackRepeat(u32 reg)</code>
Parameters	[IN] <code>reg</code> struct of I ² C register
Include	driver/i2c.h
Description	Send a NACK and then wait until it is fully transmitted on the I ² C bus.

i2c_txNackBlocking()

Usage	<code>void i2c_txNackBlocking(u32 reg)</code>
Parameters	[IN] <code>reg</code> struct of I ² C register
Include	driver/i2c.h
Description	Assert a NACK on the SDA pin.

i2c_rxAck()

Usage	<code>int i2c_rxAck(u32 reg)</code>
Parameters	[IN] <code>reg</code> struct of I ² C register
Returns	[OUT] 1 bit acknowledge
Include	driver/i2c.h
Description	Receive an acknowledge from the I ² C slave.

i2c_rxData()

Usage	<code>unit32_t i2c_rxData(u32 reg)</code>
Parameters	[IN] <code>reg</code> struct of I ² C register
Returns	[OUT] 1 byte data from I ² C slave
Include	driver/i2c.h
Description	Receive one byte data from I ² C slave.

i2c_rxNack()

Usage	<code>int i2c_rxNack(u32 reg)</code>
Parameters	[IN] <code>reg</code> struct of I ² C register
Returns	[OUT] 1 bit no acknowledge
Include	driver/i2c.h
Description	Receive no acknowledge from the I ² C slave.

I/O API Calls

read_u8()

Usage	<code>u8 read_u8(u32 address)</code>
Include	driver/io.h
Parameters	[IN] <code>address</code> SoC address
Description	Read address with unsigned 8 bits.

read_u16()

Usage	<code>u16 read_u16(u32 address)</code>
Include	driver/io.h
Parameters	[IN] <code>address</code> SoC address
Description	Read address with unsigned 16 bits.

read_u32()

Usage	<code>u32 read_u32(u32 address)</code>
Include	driver/io.h
Parameters	[IN] <code>address</code> SoC address
Description	Read address with unsigned 32 bits.

write_u8()

Usage	<code>void write_u8(u8 data, u32 address)</code>
Include	driver/io.h
Parameters	[IN] <code>data</code> SoC address data [IN] <code>address</code> SoC address
Description	Write 8 bits unsigned data to the specified address.

write_u16()

Usage	<code>void write_u16(u16 data, u32 address)</code>
Include	driver/io.h
Parameters	[IN] data SoC address data [IN] address SoC address
Description	Write 16 bits unsigned data to the specified address.

write_u32()

Usage	<code>void write_u32(u32 data, u32 address)</code>
Include	driver/io.h
Parameters	[IN] data SoC address data [IN] address SoC address
Description	Write 32 bits unsigned data to the specified address.

write_u32_ad()

Usage	<code>void write_u32_ad(u32 address, u32 data)</code>
Include	driver/io.h
Parameters	[IN] address SoC address [IN] data SoC address data
Description	Write 32 bits unsigned data to the specified address.

Machine Timer API Calls

machineTimer_setCmp()

Usage	<code>void machineTimer_setCmp(u32 p, u64 cmp)</code>
Include	driver/machineTimer.h
Parameters	[IN] <code>p</code> machine timer interrupt [IN] <code>cmp</code> machine timer compare register
Description	Set a timer value to trigger an interrupt.

machineTimer_getTime()

Usage	<code>u64 machineTimer_getTime(u32 p)</code>
Include	driver/io.h
Parameters	[IN] <code>p</code> machine timer interrupt
Returns	[OUT] timer value
Description	Gets the timer value.

machineTimer_uDelay()

Usage	<code>u64 machineTimer_uDelay(u32 usec, u32 hz, u32 reg)</code>
Include	driver/io.h
Parameters	[IN] <code>usec</code> microseconds [IN] <code>hz</code> core frequency [IN] <code>reg</code> machine timer interrupt
Description	Use the machine timer to make a delay.

PLIC API Calls

plic_set_priority()

Usage	<code>void plic_set_priority(u32 plic, u32 gateway, u32 priority)</code>
Include	driver/io.h
Parameters	[IN] <code>plic</code> PLIC register structure [IN] <code>gateway</code> interrupt type [IN] <code>priority</code> interrupt priority
Description	Set the interrupt priority.

plic_set_enable()

Usage	<code>void plic_set_enable(u32 plic, u32 target, u32 gateway, u32 enable)</code>
Include	driver/io.h
Parameters	[IN] <code>plic</code> PLIC register structure [IN] <code>target</code> HART number [IN] <code>gateway</code> interrupt type [IN] <code>enable</code>
Description	Set the interrupt enable.

plic_set_threshold()

Usage	<code>void plic_set_threshold(u32 plic, u32 target, u32 threshold)</code>
Include	driver/io.h
Parameters	[IN] <code>plic</code> PLIC register structure [IN] <code>target</code> HART number [IN] <code>threshold enable = 1</code>
Description	Masks individual interrupt sources for the HART.

plic_claim()

Usage	<code>u32 plic_claim(u32 plic, u32 target)</code>
Include	driver/io.h
Parameters	[IN] <code>plic</code> PLIC register structure [IN] <code>target</code> HART number
Description	Claim the PLIC interrupt

plic_release()

Usage	<code>void plic_release(u32 plic, u32 target, u32 gateway)</code>
Include	driver/io.h
Parameters	[IN] <code>plic</code> PLIC register structure [IN] <code>target</code> HART number [IN] <code>gateway</code> interrupt type
Description	Release the PLIC interrupt.

SPI API Calls

spi_applyConfig()

Usage	<code>void spi_applyConfig(Spi_Reg *reg, Spi_Config *config)</code>
Include	driver/spi.h
Parameters	[IN] <code>reg</code> struct of the SPI register [IN] <code>config</code> struct of the SPI configuration
Description	Applies the SPI configuration to to a register for initial configuration.

spi_cmdAvailability()

Usage	<code>spi_cmdAvailability(Spi_Reg *reg)</code>
Include	driver/spi.h
Parameters	[IN] <code>reg</code> struct of the SPI register
Description	Read the SPI command buffer.

spi_deselect()

Usage	<code>void spi_select(Spi_Reg *reg, uint32_t slaveId)</code>
Include	driver/spi.h
Parameters	[IN] <code>reg</code> struct of the SPI register [IN] <code>slaveId</code> ID for the slave
Description	De-asserts the SPI select (SS) pin.

spi_read()

Usage	<code>uint8_t spi_write(Spi_Reg *reg)</code>
Include	driver/spi.h
Parameters	[IN] <code>reg</code> struct of the SPI register
Returns	[OUT] <code>reg</code> One byte of data
Description	Receives one byte from the SPI slave.

spi_rspOccupancy()

Usage	<code>spi_rspOccupancy(Spi_Reg *reg)</code>
Include	driver/spi.h
Parameters	[IN] <code>reg</code> struct of the SPI register
Description	Read the occupancy buffer.

spi_select()

Usage	<code>void spi_select(Spi_Reg *reg, uint32_t slaveId)</code>
Include	driver/spi.h
Parameters	[IN] <code>reg</code> struct of the SPI register [IN] <code>slaveId</code> ID for the slave
Description	Asserts the SPI select (SS) pin.

spi_write()

Usage	<code>void spi_write(Spi_Reg *reg, uint8_t data)</code>
Include	driver/spi.h
Parameters	[IN] <code>reg</code> struct of the SPI register [IN] <code>data</code> 8 bits of data to send out
Description	Transfers one byte to the SPI slave.

SPI Flash Memory API Calls

spiFlash_f2m_()

Usage	<code>void spiFlash_f2m_ (Spi_Reg * spi, u32 flashAddress, u32 memoryAddress, u32 size)</code>
Include	driver/spiFlash.h
Parameters	[IN] <code>spi</code> reg struct of the SPI register [IN] <code>flashAddress</code> flash device address [IN] <code>memoryAddress</code> memory address [IN] <code>size</code> programming address size
Description	Copy data from the flash device to memory.

spiFlash_f2m()

Usage	<code>void spiFlash_f2m(Spi_Reg * spi, u32 cs, u32 flashAddress, u32 memoryAddress, u32 size)</code>
Include	driver/spiFlash.h
Parameters	[IN] <code>spi</code> reg struct of the SPI register [IN] <code>cs</code> chip select [IN] <code>flashAddress</code> flash device address [IN] <code>memoryAddress</code> memory address
Description	Copy data from the flash device to memory with chip select control.

spiFlash_f2m_withGpioCs()

Usage	<code>void spiFlash_f2m_withGpioCs(Spi_Reg * spi, Gpio_Reg *gpio, u32 cs, u32 flashAddress, u32 memoryAddress, u32 size)</code>
Include	driver/spiFlash.h
Parameters	[IN] <code>spi</code> reg struct of the SPI register [IN] <code>gpio</code> reg struct of the GPIO register [IN] <code>cs</code> chip select [IN] <code>flashAddress</code> flash device address [IN] <code>memoryAddress</code> memory address [IN] <code>size</code> programming address size
Description	Flash device from the SPI master with GPIO chip select.

spiFlash_diselect()

Usage	<code>void spiFlash_diselect(Spi_Reg *spi, u32 cs)</code>
Include	driver/spiFlash.h
Parameters	[IN] <code>spi</code> reg struct of the SPI register [IN] <code>cs</code> chip select
Description	De-asserts the SPI flash device from the master chip select.

spiFlash_deselect_withGpioCs()

Usage	<code>void spiFlash_deselect_withGpioCs(Gpio_Reg *gpio, u32 cs)</code>
Include	driver/spiFlash.h
Parameters	[IN] <code>gpio</code> reg struct of the GPIO register [IN] <code>cs</code> chip select
Description	De-asserts the SPI flash device from the master with the GPIO chip select.

spiFlash_init_()

Usage	<code>void spiFlash_init_(Spi_Reg * spi)</code>
Include	driver/spiFlash.h
Parameters	[IN] <code>spi</code> reg struct of the SPI register
Description	Initialize the SPI reg struct.

spiFlash_init()

Usage	<code>void spiFlash_init(Spi_Reg * spi, u32 cs)</code>
Include	driver/spiFlash.h
Parameters	[IN] <code>spi</code> reg struct of the SPI register [IN] <code>cs</code> chip select
Description	Initialize the SPI reg struct with chip select de-asserted.

spiFlash_init_withGpioCs()

Usage	<code>void spiFlash_init_withGpioCs(Spi_Reg * spi, Gpio_Reg *gpio, u32 cs)</code>
Include	driver/spiFlash.h
Parameters	[IN] <code>spi</code> reg struct of the SPI register [IN] <code>gpio</code> reg struct of the GPIO register [IN] <code>cs</code> chip select
Description	Initialize the SPI reg struct with GPIO chip select de-asserted.

spiFlash_select()

Usage	<code>void spiFlash_select(Spi_Reg *spi, u32 cs)</code>
Include	driver/spiFlash.h
Parameters	[IN] <code>spi</code> reg struct of the SPI register [IN] <code>cs</code> chip select
Description	Select the SPI flash device.

spiFlash_select_withGpioCs()

Usage	<code>spiFlash_select_withGpioCs(Gpio_Reg *gpio, u32 cs)</code>
Include	driver/spiFlash.h
Parameters	[IN] <code>gpio</code> reg struct of the GPIO register [IN] <code>cs</code> chip select
Description	Select the SPI flash device with the GPIO chip select.

spiFlash_wake_()

Usage	<code>void spiFlash_wake_(Spi_Reg * spi)</code>
Include	driver/spiFlash.h
Parameters	[IN] <code>spi</code> reg struct of the SPI register
Description	Release power down from the SPI master.

spiFlash_wake()

Usage	<code>void spiFlash_wake(Spi_Reg * spi, u32 cs)</code>
Include	driver/spiFlash.h
Parameters	[IN] <code>spi</code> reg struct of the SPI register [IN] <code>cs</code> chip select
Description	Release power down from the SPI master with chip select.

spiFlash_wake_withGpioCs()

Usage	<code>void spiFlash_wake_withGpioCs(Spi_Reg * spi, Gpio_Reg *gpio, u32 cs)</code>
Include	driver/spiFlash.h
Parameters	[IN] <code>spi</code> reg struct of the SPI register [IN] <code>gpio</code> reg struct of the GPIO register [IN] <code>cs</code> chip select
Description	Release power down from the SPI master with the GPIO chip select.

UART API Calls

uart_applyConfig()

Usage	<code>char uart_applyConfig(Uart_Reg *reg, Uart_Config *config)</code>
Include	driver/uart.h
Parameters	[IN] <code>reg</code> struct of the UART register [IN] <code>config</code> struct of the UART configuration
Description	Applies the UART configuration to a register for initial configuration.

uart_emptyInterruptEna()

Usage	<code>uart_emptyInterruptEna(u32 reg char ena)</code>
Include	driver/uart.h
Parameters	[IN] <code>reg</code> struct of the UART register [IN] <code>ena</code> Enable interrupt
Description	Enable the TX FIFO empty interrupt.

uart_NotemptyInterruptEna()

Usage	<code>uart_NotemptyInterruptEna(u32 reg char ena)</code>
Include	driver/uart.h
Parameters	[IN] <code>reg</code> struct of the UART register [IN] <code>ena</code> Enable interrupt
Description	Enable the RX FIFO not empty interrupt.

uart_read()

Usage	<code>char uart_read(Uart_Reg *reg)</code>
Include	driver/uart.h
Parameters	[IN] <code>reg</code> struct of the UART register
Returns	[OUT] <code>reg</code> character that is read
Description	Reads a character from the UART slave.

uart_readOccupancy()

Usage	<code>uint32_t uart_readOccupancy(Uart_Reg *reg)</code>
Include	driver/uart.h
Parameters	[IN] <code>reg</code> struct of the UART register
Description	Read the number of bytes in the RX FIFO.

uart_status_read()

Usage	<code>uart_status_read(u32 reg)</code>
Include	driver/uart.h
Parameters	[IN] <code>reg</code> struct of the UART register
Returns	[OUT] 32-bit status register from the UART
Description	Read the UART status.

uart_status_write()

Usage	<code>uart_status_write(u32 reg)</code>
Include	driver/uart.h
Parameters	[IN] <code>reg</code> struct of the UART register [IN] <code>data</code> input data for the UART status.
Returns	[OUT] 32-bit status register from the UART
Description	Write the UART status.

uart_write()

Usage	<code>void uart_write(Uart_Reg *reg, char data)</code>
Include	driver/uart.h
Parameters	[IN] <code>reg</code> struct of the UART register [IN] <code>data</code> write a character
Description	Write a character to the UART.

uart_writeStr()

Usage	<code>void uart_writeStr(Uart_Reg *reg, char* str)</code>
Include	driver/uart.h
Parameters	[IN] <code>reg</code> struct of the UART register [IN] <code>str</code> string to write
Description	Write a string to the UART TX.

uart_writeAvailability()

Usage	<code>uart_writeAvailability(Uart_Reg *reg)</code>
Include	driver/uart.h
Parameters	[IN] <code>reg</code> struct of the UART register
Description	UART read/write FIFO.

Handling Interrupts

There are two kinds of interrupts, trap vectors and PLIC interrupts, and you handle them using different methods.

Figure 6: Types of Interrupts

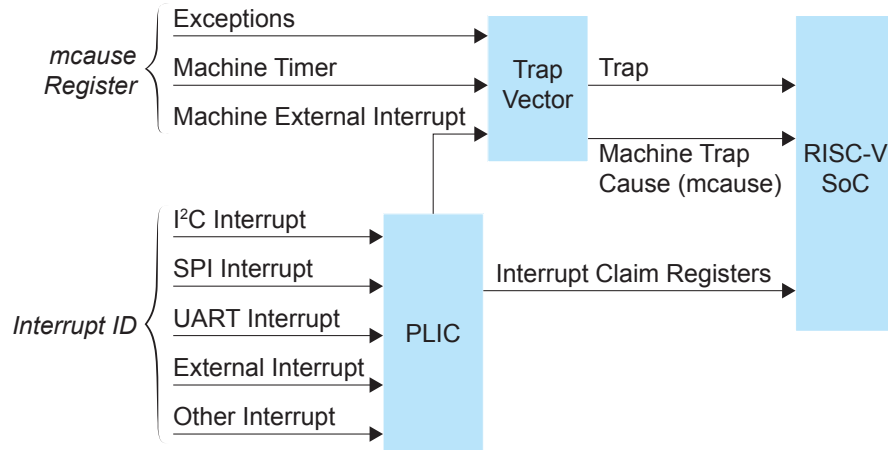

Trap Vectors

Trap vectors trap interrupts or exceptions from the system. Read the Machine Cause Register (mcause) to identify which type of interrupt or exception the system is generating. Refer to "Machine Cause Register (mcause): 0x342" in the data sheet for your SoC for a list of the exceptions and interrupts used for trap vectors. The following flow chart explains how to handle trap vectors.

For CAUSE_MACHINE_EXTERNAL, it will call the subroutine to process the PLIC level interrupts.

Figure 7: Handling Trap Vectors

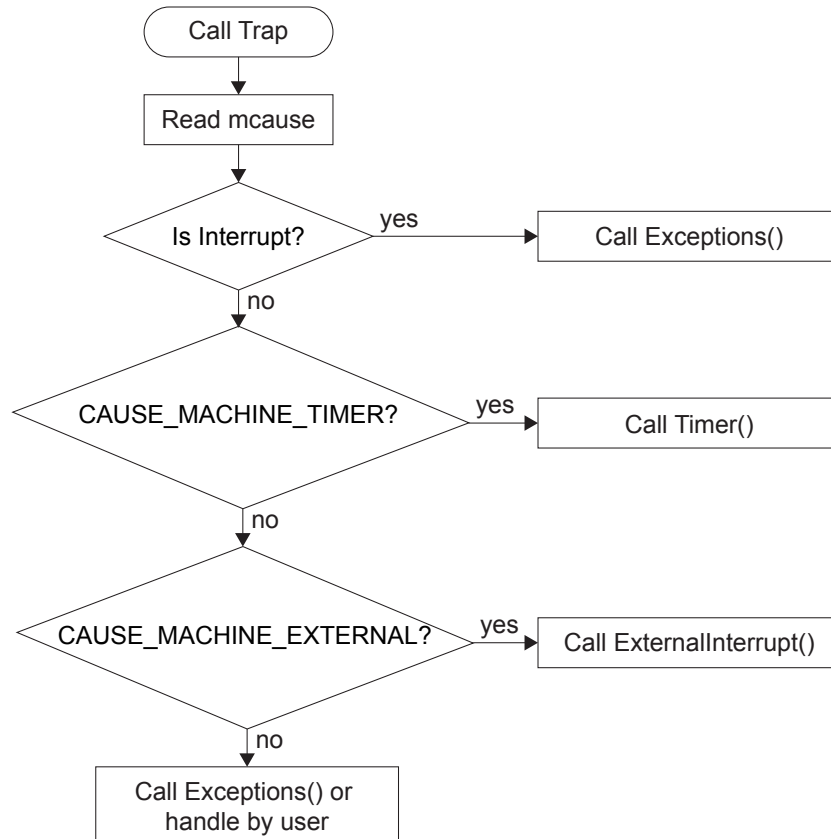

PLIC Interrupts

The PLIC collects external interrupts and is also used for CAUSE_MACHINE_EXTERNAL cases. Read the interrupt claim registers (PLIC claim) to identify the source of the external interrupt. Refer to [Address Map](#) on page 29 for a list of the interrupt IDs.

The following flow chart shows how the PLIC handles interrupts. The PLIC identifies the interrupt ID and processes the corresponding interrupts.

Figure 8: Handling PLIC Interrupts

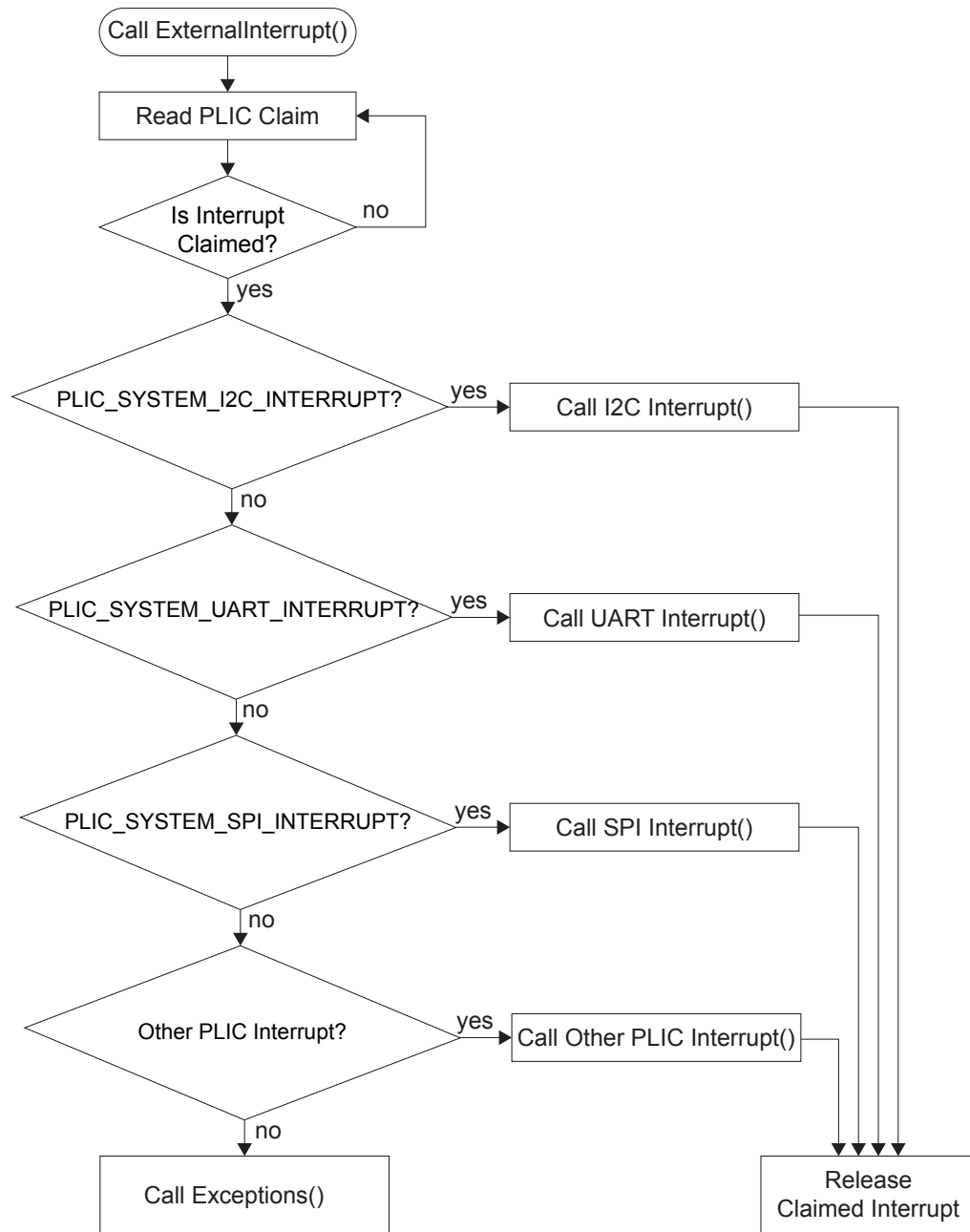

Revision History

Table 7: Revision History

Date	Version	Description
November 2021	1.1	Added information about the flow for handling interrupts in the API Reference chapter. (DOC-398) Updated UART and GPIO API calls. Added link to OpenJDK (DOC-457)
March 2021	1.0	Initial release.